

ESCHER

mixers



PM line

Planetary mixers
Mescolatori planetari
Batteurs mélangeurs



PM line

20_40_60_80 l

ESCHER
mixers



Mixer which combines a sturdy construction with a modern design. Silent mechanism during operation. Guarantees thorough mixing results. User-friendly and easy to clean for a high level of hygiene.

20, 40 and 60-liter models with variable speed. Simple-to-use lever-operated bowl support system.

80-liter model with standard automatic lifting of the bowl. Available with 3 pre-set speeds or optional variable speed.

Very easy tool fixing/releasing system thanks to the absence of lock rings. All the components in contact with food are in stainless steel.

Supplied with stainless steel bowl and tools (hook, beater and whisk). 10-20-40-60-liter reductions with bowl and 3 tools.

Rotating frontal stainless steel grid. Manually adjustable timer.

Options available: stainless steel finish of the entire machine, electronic controls or touch screen, heavy-wire whisk, scraper and bowl trolley.

Macchina che combina una concezione robusta ad un design moderno. Possiede una meccanica silenziosa e garantisce risultati di mescolazione accurati. Facilità di utilizzo e di pulizia per un alto livello di igiene. Modelli 20,40 e 60 litri con velocità variabile. Supporto vasca sollevamento manuale.

Modello 80 litri con sollevamento automatico della vasca di serie. Disponibile con 3 velocità pre-impostate o con velocità variabile su richiesta.

Operazioni di aggancio/sgancio utensili facilitate dall'assenza di anelli di fissaggio. Tutti le parti in contatto con gli alimenti sono in acciaio inossidabile.

Equipaggiamento standard: vasca e utensili in acciaio inox (spirale, spatola e frusta). Riduzioni 10-20-40-60 litri con vasca e 3 utensili.

Griglia frontale rotante in acciaio inox. Timer a regolazione manuale.

Opzioni disponibili: esecuzione completa della macchina in acciaio inox, controlli elettronici o touch screen, frusta con fili rinforzati, raschiatore e carrello vasca.

Machine qui combine une conception robuste à un design moderne. Mécanique silencieuse et résultats de mélange minutieux. Utilisation et nettoyage simples pour un niveau d'hygiène élevé.

Modèles 20, 40 et 60 litres avec vitesse variable. Support de la cuve actionné par levier.

Modèle 80 litres avec soulèvement automatique standard de la cuve. Disponible avec 3 vitesses pré-réglées ou vitesse variable en option.

Opérations d'accrochage/décrochage des outils remarquablement facilitées par l'absence d'anneaux de fixation. Tous les composants en contact avec les produits alimentaires sont en acier inox.

Equipement standard : cuve et outils en acier inox (spirale, palette et fouet). Réductions 10-20-40-60 litres disponibles avec cuve et 3 outils.

Grille frontale rotative en acier inox. Minuterie à réglage manuel.

Options disponibles: machine entièrement réalisée en acier inox, contrôles électroniques ou avec écran tactile, fouet à fils renforcés, racleur et chariot cuve.

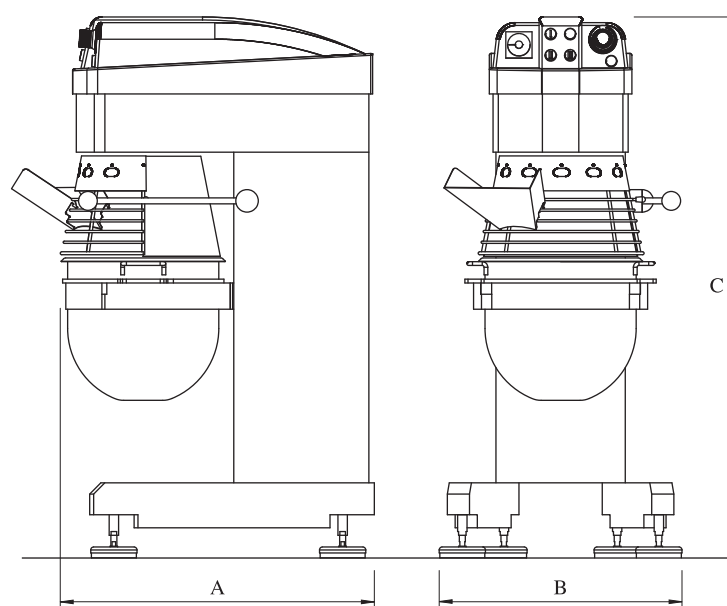

Model Modello Modèle	Capacity Capacità Contenance	Reduction Riduzione Réduction	Power Potenza Puissance	Dimensions Dimensioni Dimensions			Weight Peso Poids	Speed Velocità Vitesses	Tool speed Velocità utensile Vitesse outil
	l	l	Kw	A	B	C	Kg		rpm
PM 20-V/table	20	10	0,75	660 x 450 x 815 mm			105	inverter	100 - 400
PM 20-V/stand	20	10	0,75	660 x 450 x 1215 mm			125	inverter	100 - 400
PM 40-V	40	20	1,5	650 x 840 x 1445 mm			270	inverter	82 - 323
PM 60-V	60	40	2,2	760 x 910 x 1475 mm			360	inverter	82 - 323
PM 80-3	80	60	3,1 / 2,5 / 1,2	760 x 910 x 1475 mm			385	3	82 - 161 - 323
PM 80-V	80	60	3	760 x 910 x 1475 mm			385	inverter	82 - 323

ESCHER MIXERS srl
 36015 Schio · Vicenza · Italy · Via Lago di Vico, 37
 Tel. +39 0445 576.692 · Fax +39 0445 577.280
 mail@eschermixers.com

www.eschermixers.com

ESCHER
 mixers